



Sanierung von Bolzenverbindungen an Offshore-Fundamenten Innovative Spezialabdichtungen von Flanschmanschetten an 54 Monopils

Klaus Deininger

KTW Umweltschutztechnik Weimar

**28. Windenergietage
05. – 07.11.2019 in Potsdam**



Hochelastische Abdichtungen für Windenergiefundamente



Sanierung von Sockelfundamenten mit hochelastischer Polyurethan-Abdichtung



KTW Umweltschutztechnik GmbH

Elastische Komplettabdichtung mit UV-Schutz und Wurzelfestigkeit an Ankersystemen



KTW Umweltschutztechnik GmbH

Verpressen von Sockelfundamenten



KTW Umweltschutztechnik GmbH

Sanierung von Tragwerken mit Aufzugstechnik

















P 12268 DE

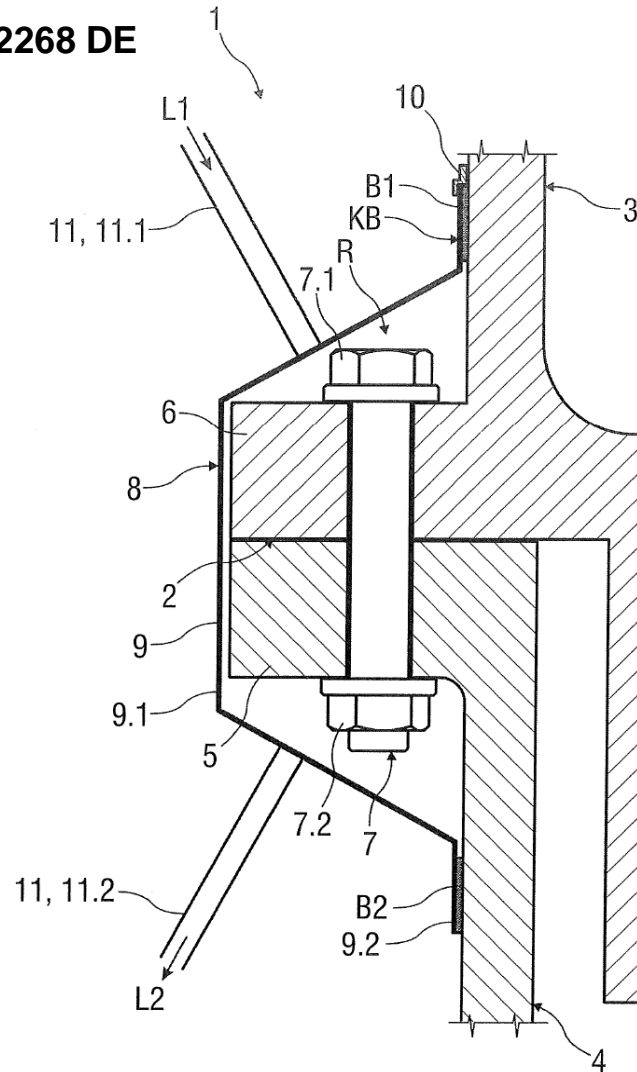























P 12268 DE

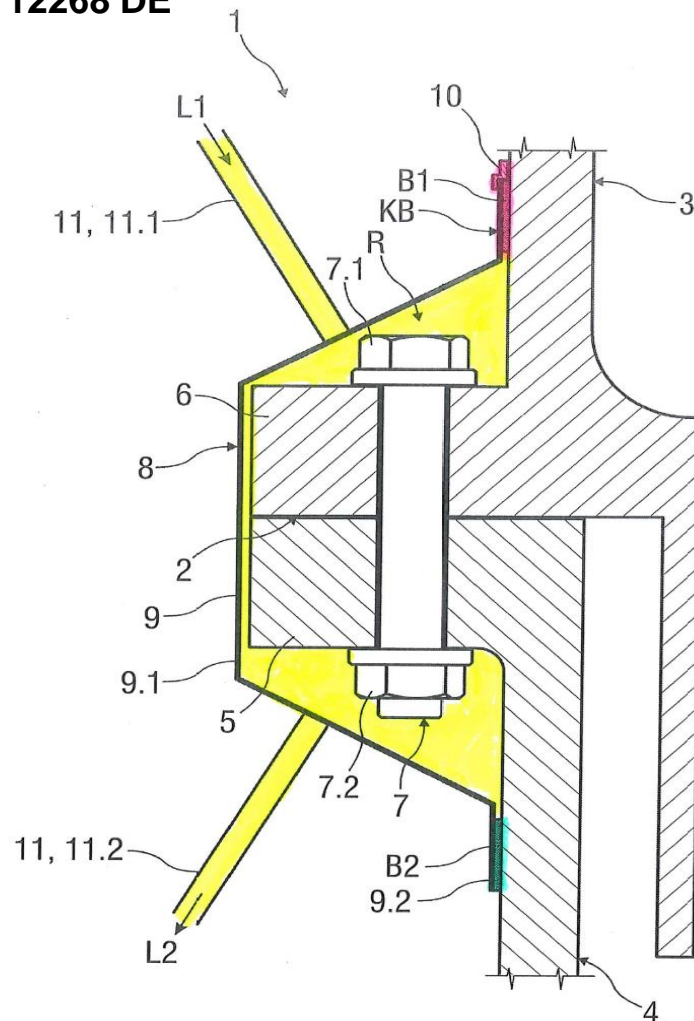

klimateiert

verklebt

Magnetschiene





Danke für Ihre Aufmerksamkeit!
www.ktweimar.de