

Presented by

Stefan Bill

Managing Director,
REWITEC GmbH

12. November 2021

Lebensdauererlängerung von Hauptlagern - wissenschaftliche Berechnung und praktische Umsetzung

Forum 17, Profit am Wind

Agenda

- ⇒ Company and products
- ⇒ Technology
- ⇒ Scientific tests
- ⇒ Examples of application
- ⇒ Bearing lifetime calculation
- ⇒ Conclusion



Typical damage to gears & bearings

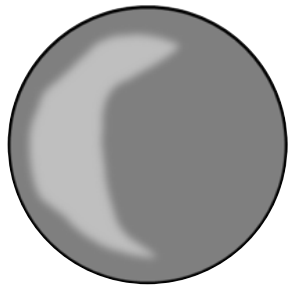

Micropitting/
Grey staining

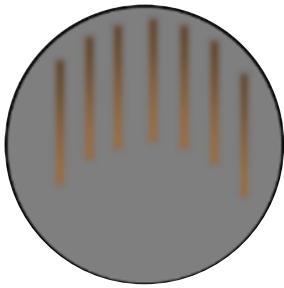

Fretting
corrosion

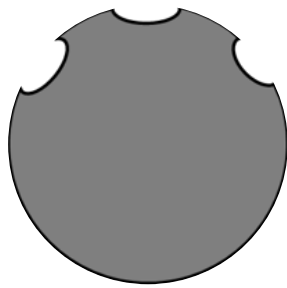

False
brinelling

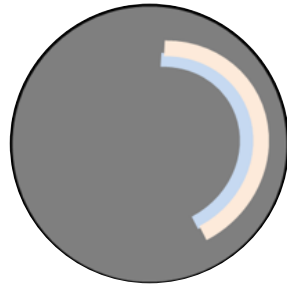

Smearing and
scuffing

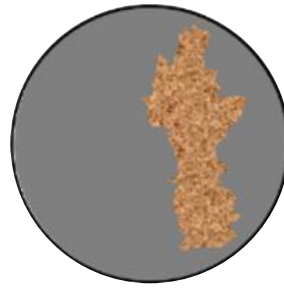

Chemical
corrosion

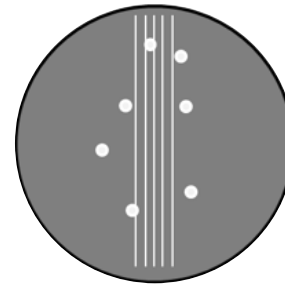

Electric
damage

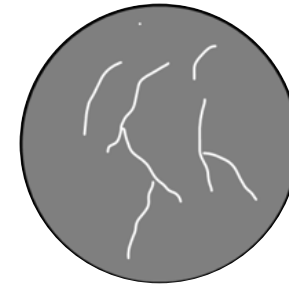

White etching
areas/cracks

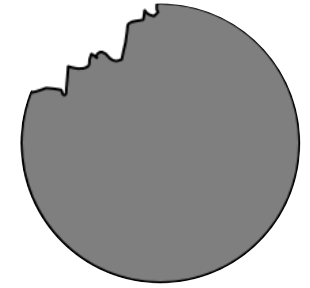

Macropitting

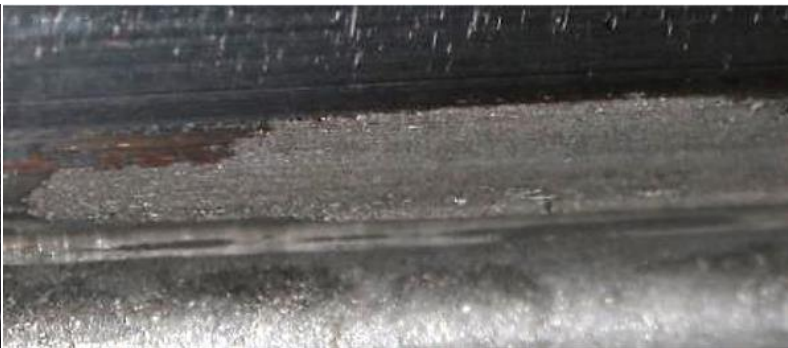
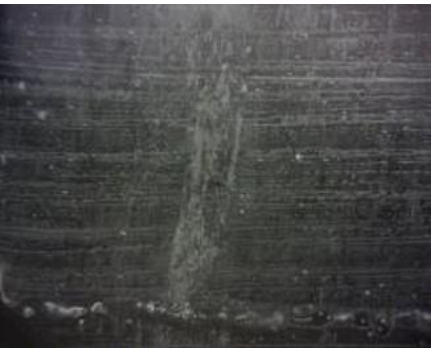

Company and products

Key facts about REWITEC

- ⇒ Founded in 2003
- ⇒ Close cooperation with universities and research institutes
- ⇒ Supported by the German Government
- ⇒ Patents in Europe, China, USA
- ⇒ Acquisition by CRODA in 2019



Target markets



⇒ Wind energy

- ⇒ Onshore
- ⇒ Offshore



⇒ Industry

- ⇒ Steel
- ⇒ Cement
- ⇒ Mining
- ⇒ Oil, Gas



⇒ Marine

- ⇒ Shipping
- ⇒ Barges
- ⇒ Yachts
- ⇒ Submarine



⇒ Automotive

- ⇒ Consumer
- ⇒ OEM
- ⇒ Motorcycles
- ⇒ Racing
- ⇒ Classic cars

Examples of application

⇒ Over 3,000 successfully treated wind turbines globally



DuraGear™



Gears



GR400



Bearings

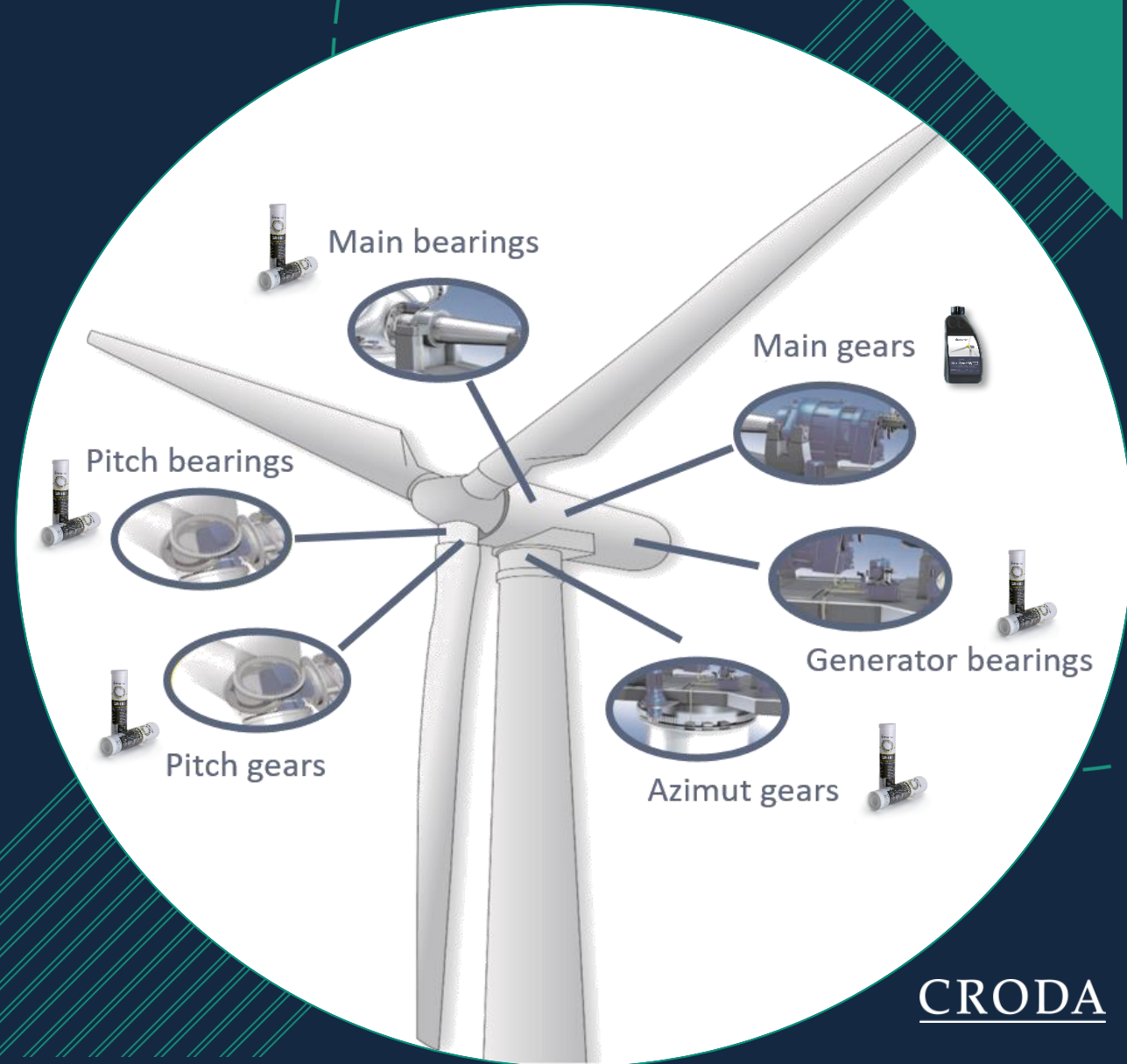

REWITEC technology

Phyllosilicate based particle additive

- ⇒ Platelet-shaped particles with layered crystal structure
 - ⇒ Si-O and Al-O based layers
 - ⇒ Strong *covalent* bonds within the layer
 - ⇒ Weak *van der Waals* interaction between the layers
- ⇒ Easy shearing between the layers
 - ⇒ **Friction reduction**
- ⇒ Big specific area with high adsorption ability
 - ⇒ covering the surface, filling the holes
 - ⇒ **Protective, repairing and smoothing effect**
- ⇒ Particle size $d_{90} = 4 \mu\text{m}$
- ⇒ Soft material: Mohs Hardness Scale 2.5 (like fingernail!)

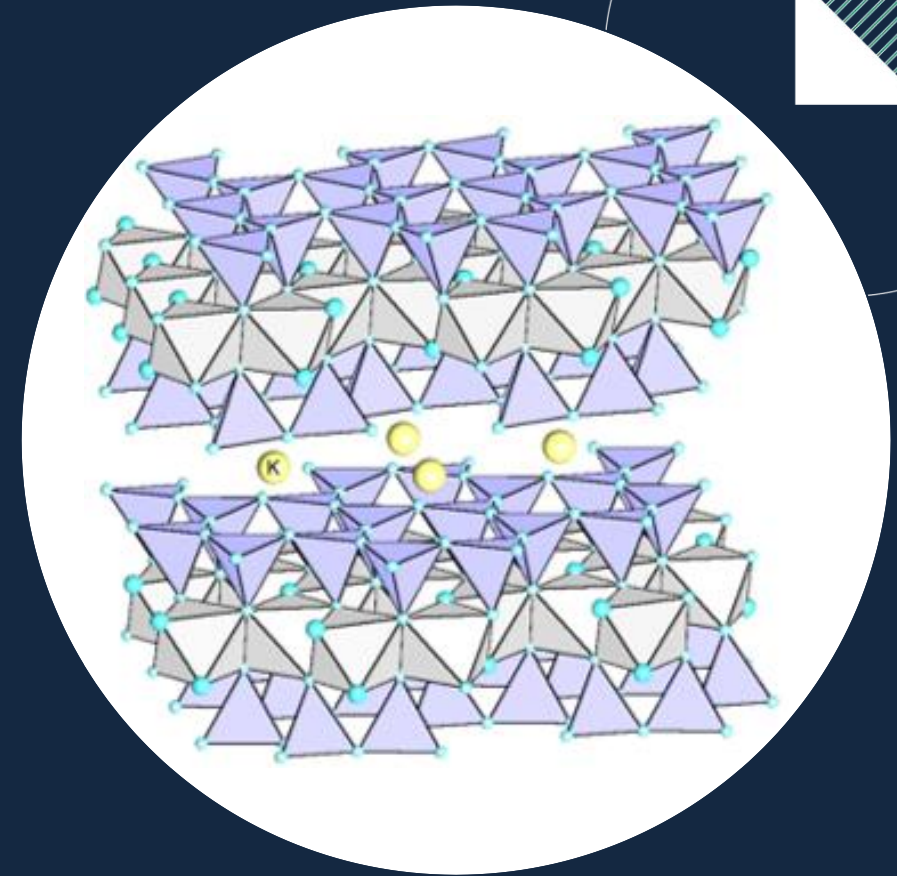

Our scientific paper:

- ⇒ "Tribological properties of a phyllosilicate based microparticle oil additive"
- ⇒ Chizhik et al., Wear 426–427 (2019) 835–844

How REWITEC works

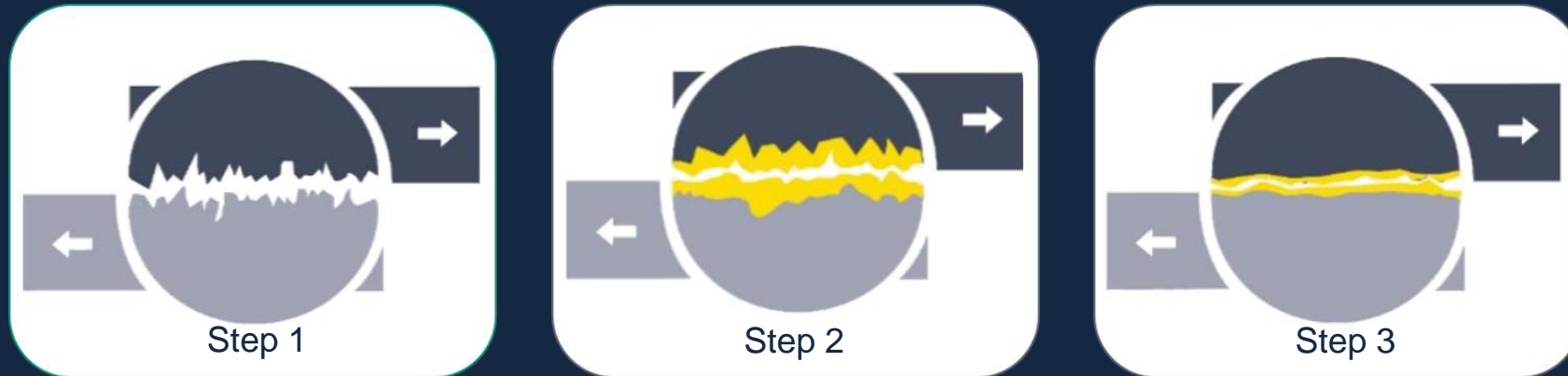

Significant reduction of friction, wear, roughness and temperature

⇒ **Advantages:**

- ⇒ Compatibility to all common lubricants
- ⇒ Temperature independent
- ⇒ No chemical interactions with other lubricant parts
- ⇒ Low dosage

Scientific tests



Supported by:



on the basis of a decision by the German Bundestag

2-Disc assembly rolling wear test – gear oils

- ⇒ Stress value: 1 GPa (normal force 2150 N)
- ⇒ Rotating speed: 424 rpm / 339 rpm, slip 20 %
- ⇒ Test-duration: 39,3 h
- ⇒ Temperature: oil inlet temperature 60 °C
- ⇒ Friction coefficient: μ =normal force/friction force

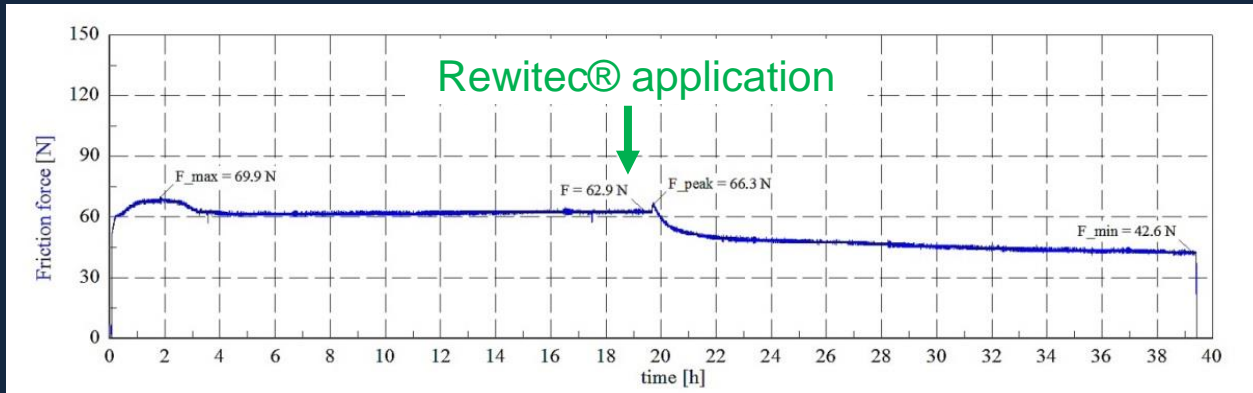

Castrol Optigear Synthetic X320

Oil	Friction reduction	Roughness reduction
Castrol Optigear Synthetic X320	33 %	41 %
Mobilgear SHC XMP 320	35 %	44 %
Klübersynth GEM 4-320N	40 %	54 %
Fuchs Unisyn CLP 320	36 %	50 %
Amsoil PTN 320	46 %	18 %
Shell Omala S4 GX 320	42 %	25 %
Klüberbio EG 2-150	55 %	40 %
Fuchs Pentosin EG FFL-7A	41 %	35 %
Automotive racing gear oil	55 %	40 %

SRV – FZG simulation

Temperature: 98°C
 Frequency: 50 Hz
 Stroke Length : 4 mm

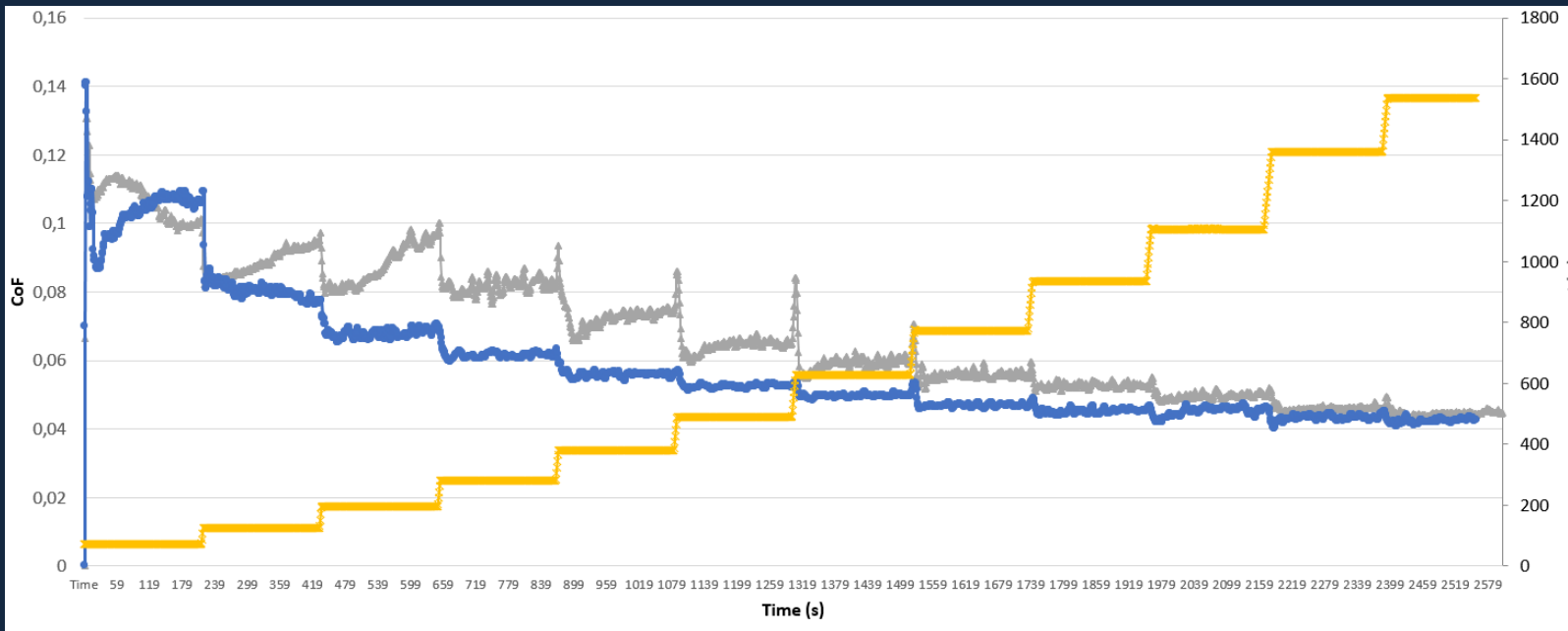



OPTIMOL Testing concept for gear oils

Step tests with modified parameters

Hertzian surface pressure [N/mm ²]	FZG load step	SRV® normal force [N]
146	1	7
295	2	28
474	3	73
621	4	126
773	5	195
929	6	282
1080	7	381
1223	8	489
1386	9	628
1539	10	774
1691	11	934
1841	12	1107
2040	13	1360
2170	14	1538

SRV® Technology Platform 10 Excellence in Tribology

-  Castrol X320
-  Castrol X320 + Rewitec
-  Load

⇒ 12 % wear reduction with REWITEC

⇒ Up to 30 % friction reduction with REWITEC

FE-8 roller bearing test

- ⇒ Speed: 7.5 rpm
- ⇒ Test duration: 80 h
- ⇒ Temperature: 80°C
- ⇒ Load: 80 kN

Advantages with REWITEC:

- ⇒ 17 % less wear
- ⇒ Smoother surface
- ⇒ Better load distribution
- ⇒ Protection for rolling elements and rings

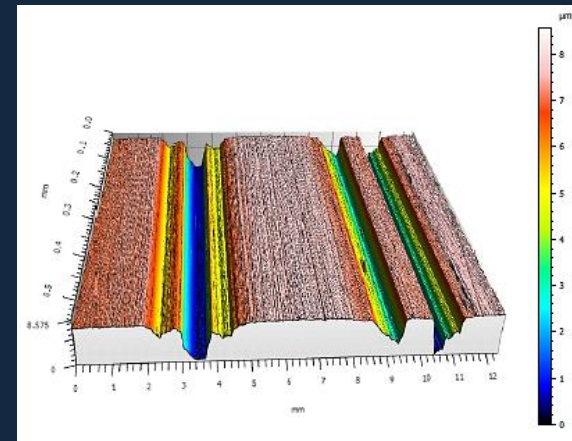
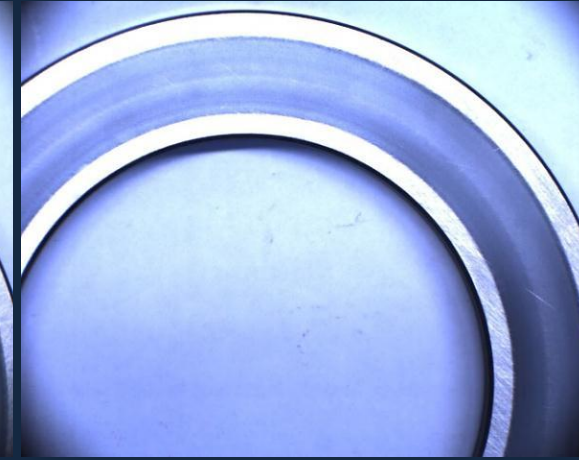

Castrol X320 **without**
REWITEC®

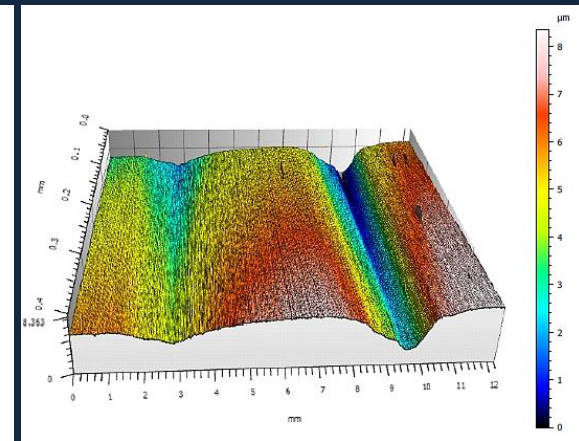

Castrol X320 **with**
REWITEC®

MTM test bench - grease test



- ⇒ Load: 70 N
- ⇒ Temperature: 23°C
- ⇒ Time: 172 s

700 mm/s

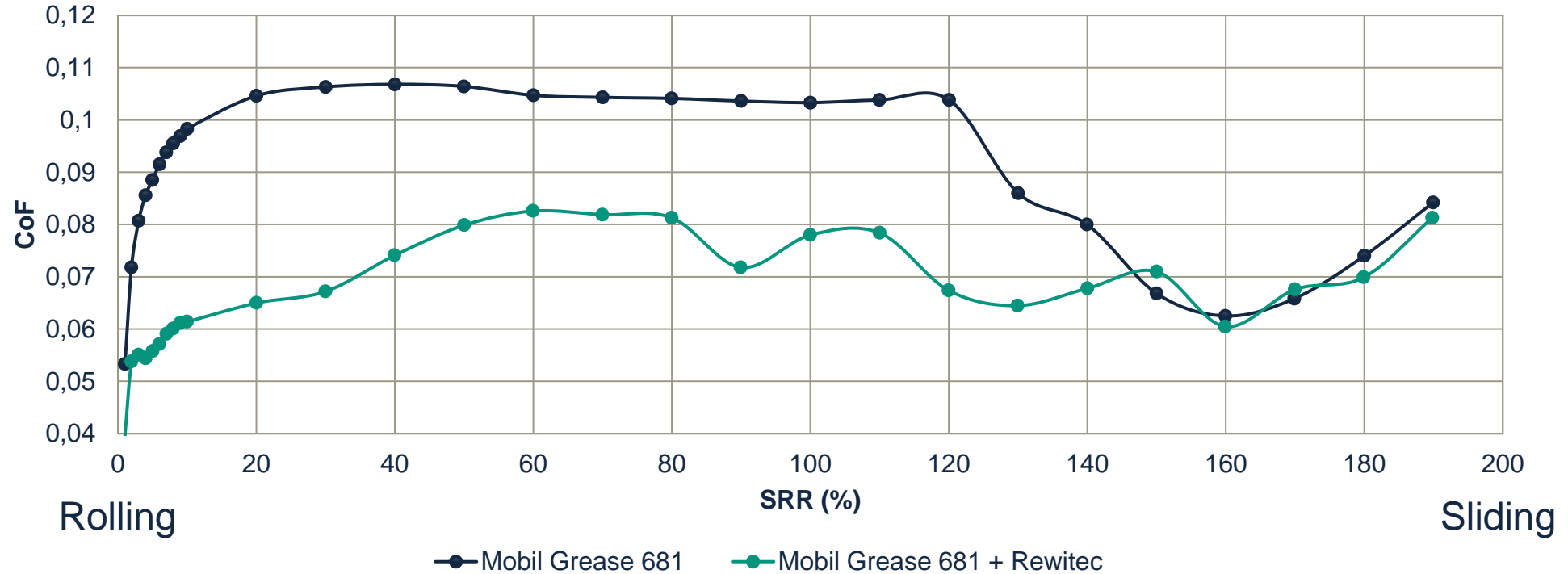

⇒ Up to 38 % friction reduction with REWITEC

False-Brinelling test – For pitch bearing evaluation

- ⇒ Frequency: 25 Hz
- ⇒ Oszillation angle: +/- 0.5° -> +/- 3.0°
- ⇒ Axial load: 3 kN to 4 balls (750 N per ball)
- ⇒ Temperature: room temperature
- ⇒ Test bearing: ARKL Type 51206 with 4 rolling elements

Fuchs LX460

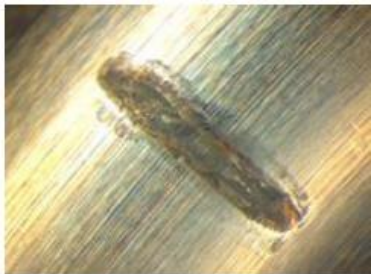

pre-damaging
(1.3 h; +/- 0.5°)

Fuchs LX460



Run after the damaging
(3 h; +/- 3°)

Fuchs LX460 + **REWITEC™**

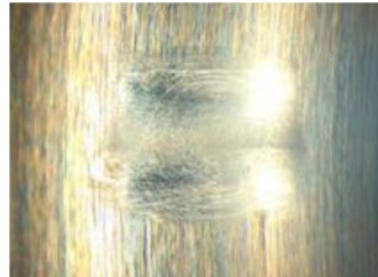

Test Rig



Test specimen



Static loading

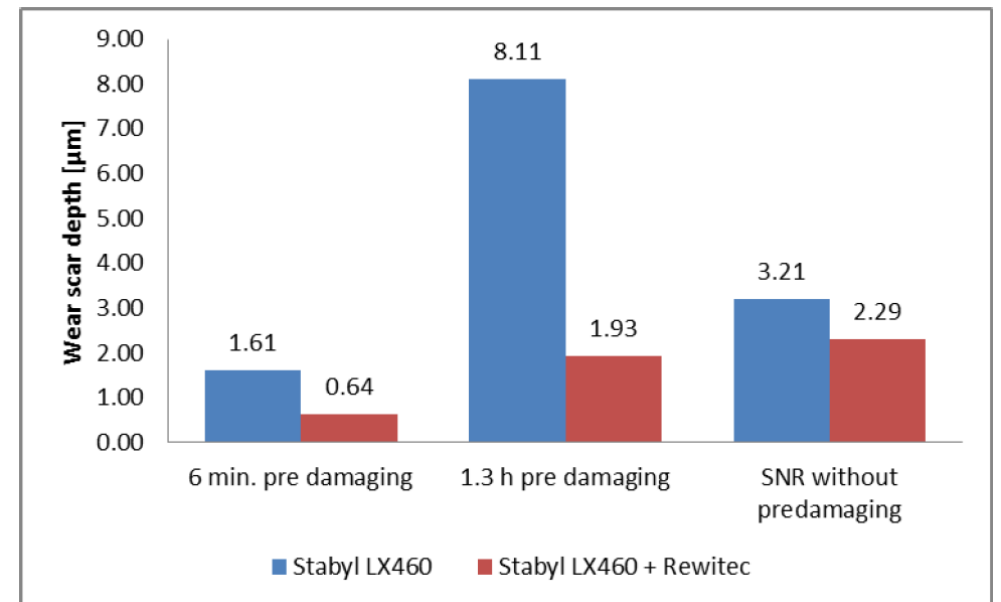

Examples of application

Coating and analysis of a main bearing (outer ring) GE 1.5 wind turbine

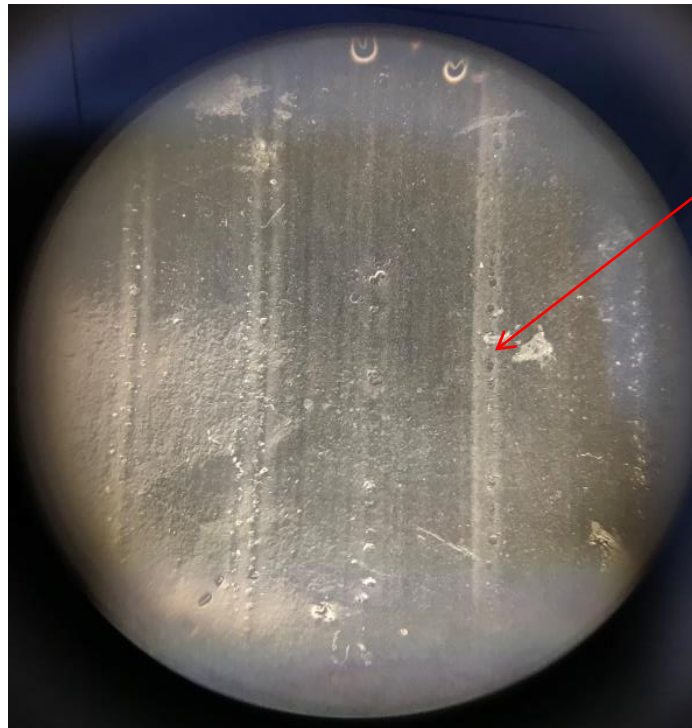

⇒ Picture: Before wind turbine was treated with REWITEC™

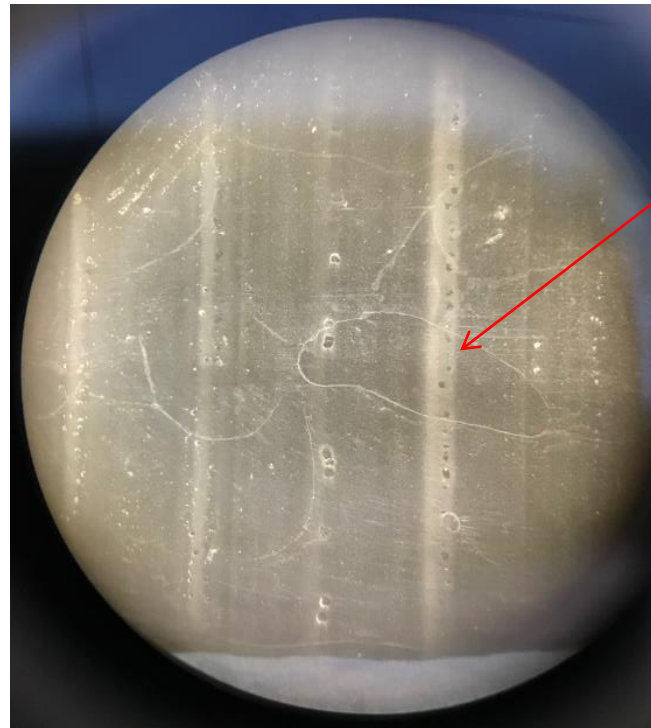

⇒ Picture: 5 months after wind turbine was treated with REWITEC™

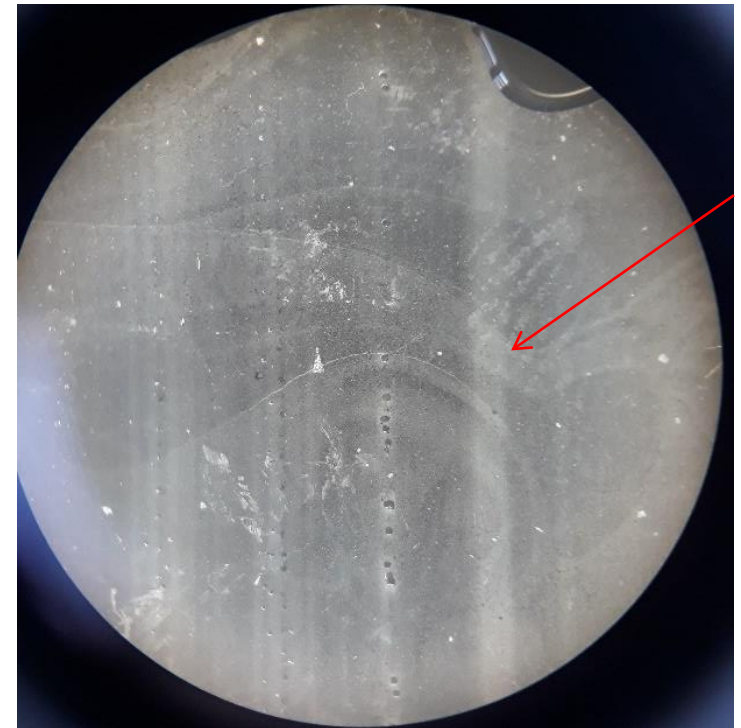

⇒ Picture: 12 months after wind turbine was treated with REWITEC™

Coating and analysis of a main bearing (outer ring) GE 1.5 wind turbine



⇒ Picture: Before wind turbine was treated with REWITEC™

⇒ Ra = 0,556 μm (within the track)

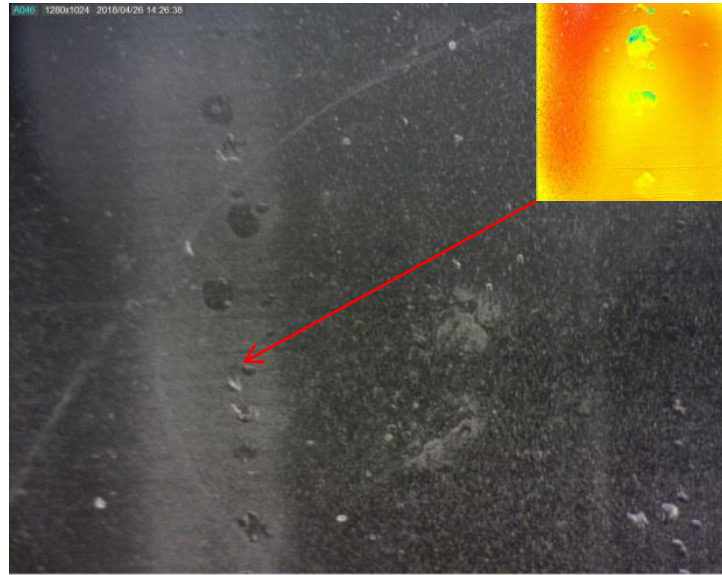

⇒ Picture: 5 months after wind turbine was treated with REWITEC™

⇒ Ra = 0,403 μm (within the track)



⇒ Picture: 12 months after wind turbine was treated with REWITEC™

⇒ Ra = 0,225 μm (within the track)

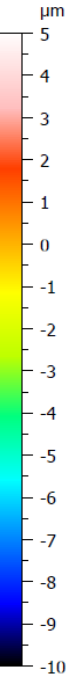

Main bearing (outer race) GE 1.5 wind turbine



⇒ **Before** wind turbine was treated with REWITEC™



⇒ 6 months **after** wind turbine was treated with REWITEC™

Coating and analysis of a main bearing GE 1.5 wind turbine

Roughness	Before	After	Difference
S_a	3.00 μm	1.47 μm	- 51 %
S_z	56.7 μm	19.8 μm	- 65 %
R_a	0.789 μm	0.600 μm	- 24 %
R_z	4.10 μm	3.38 μm	- 18 %

Before Rewitec application (05.06.20)

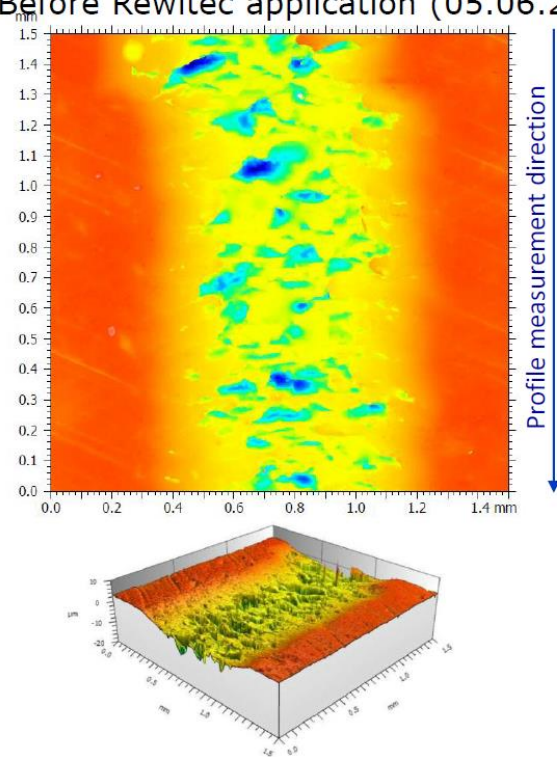

After Rewitec application (06.01.21)

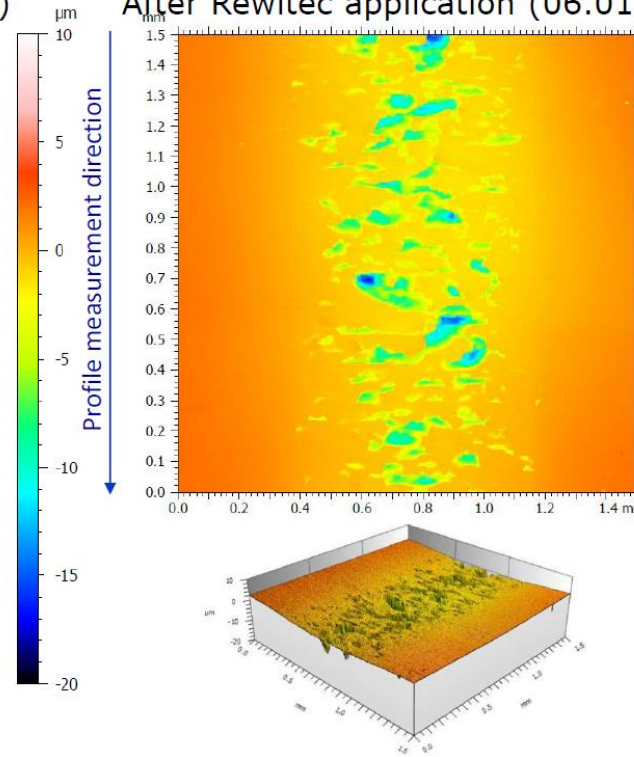

Coating and analysis of a main bearing GE 1.5 wind turbine

Roughness	Before	After	Difference
S_a	0.266 μm	0.159 μm	- 40 %
S_z	22.2 μm	11.6 μm	- 48 %
R_a	0.145 μm	0.064 μm	- 56 %
R_z	1.31 μm	0.767 μm	- 41 %

Before Rewitec application (05.06.20)

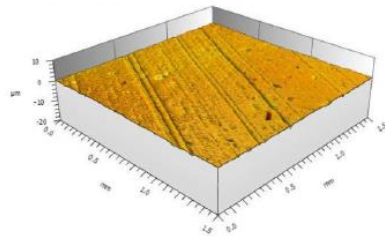
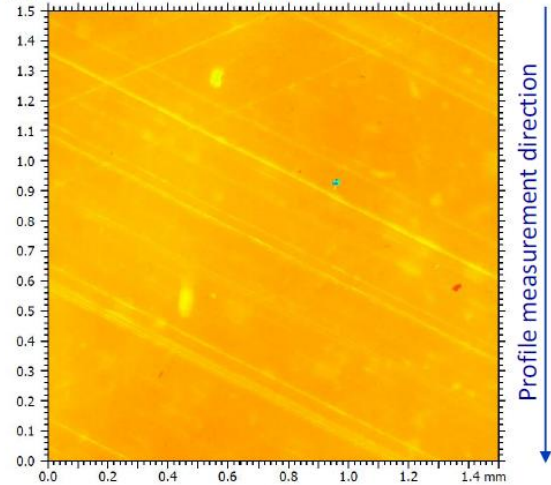

After Rewitec application (06.01.21)

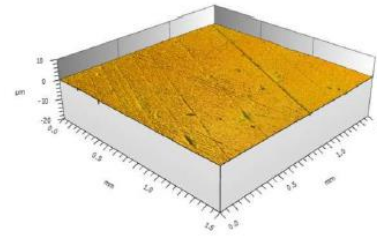
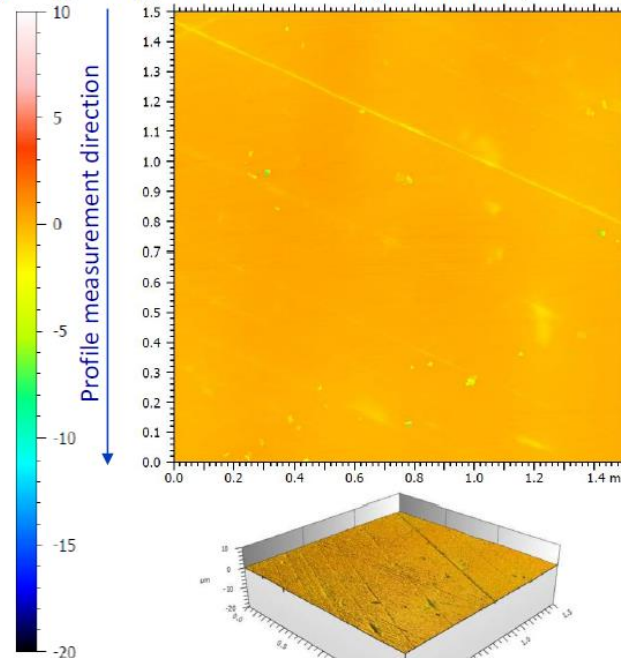

Wind turbine 1.5 MW GE 1.5 Planetary Bearing

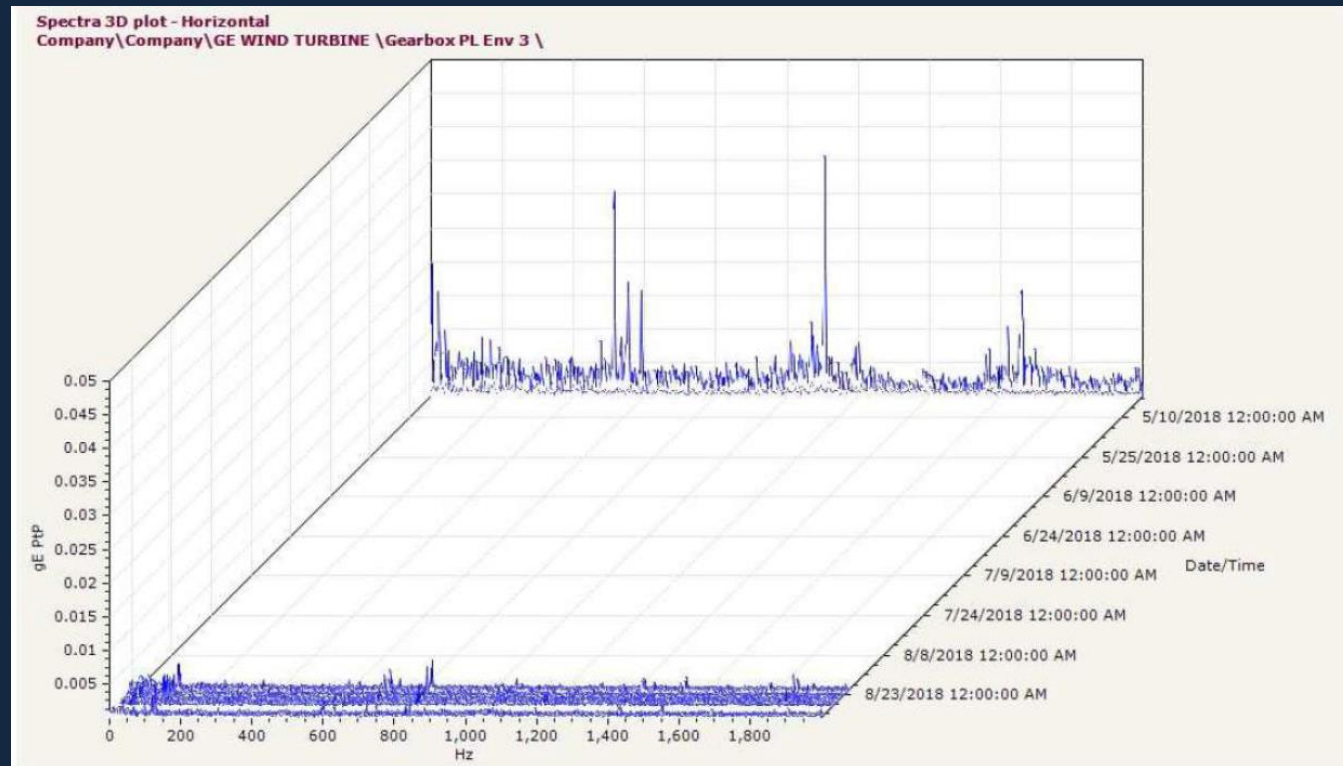

PLANETARY BEARING MEASUREMENT PRE- TREATMENT IS IN BACK, POST IS IN THE FOREGROUND

Wind turbine 1.5 MW GE 1.5

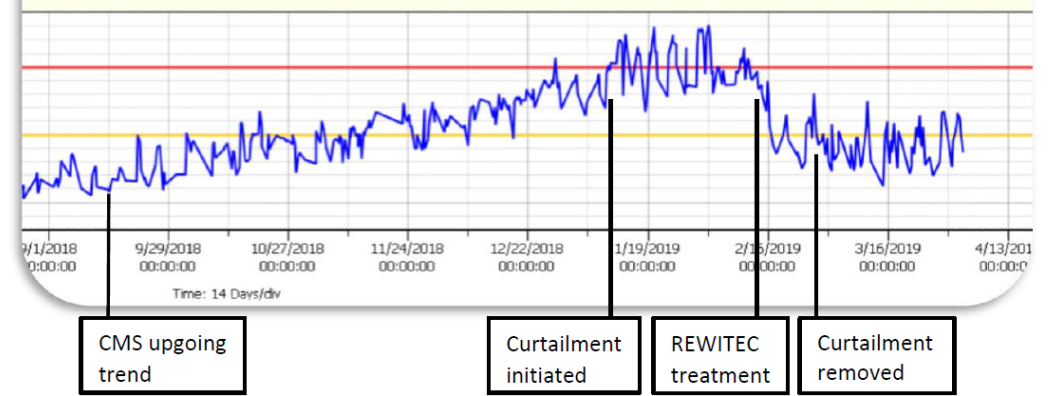

⇒ Before REWITEC™ treatment



⇒ After REWITEC™ treatment

Sentient Science

⇒ Lifetime calculation
model by using
REWITECTM



Sentient Science Lifetime Calculation

⇒ Calculation based on bearing geometry, friction coefficient and surface topography:

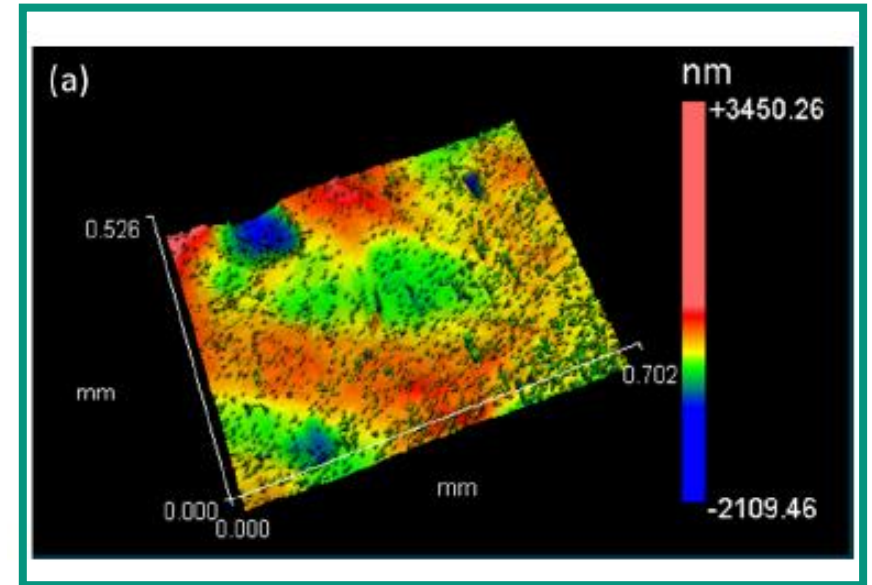
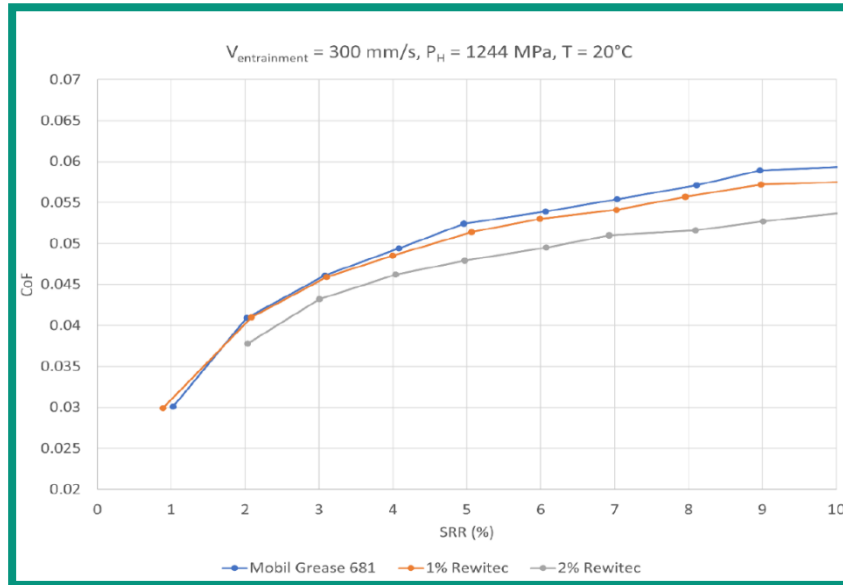
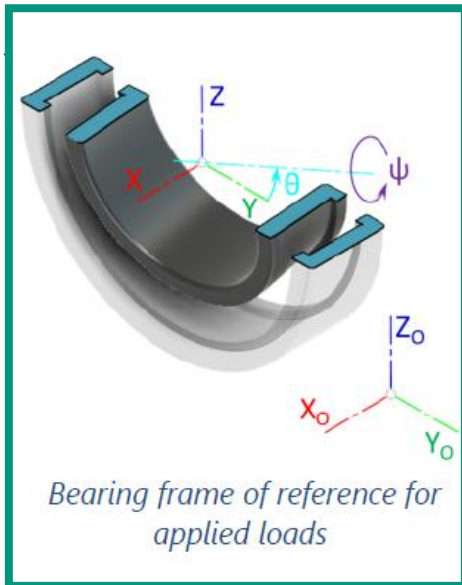

Sentient Science Lifetime calculation

⇒ Mainshaft Bearing Life Extension by REWITEC™ GR400 Grease using Sentient Science' DigitalClone®

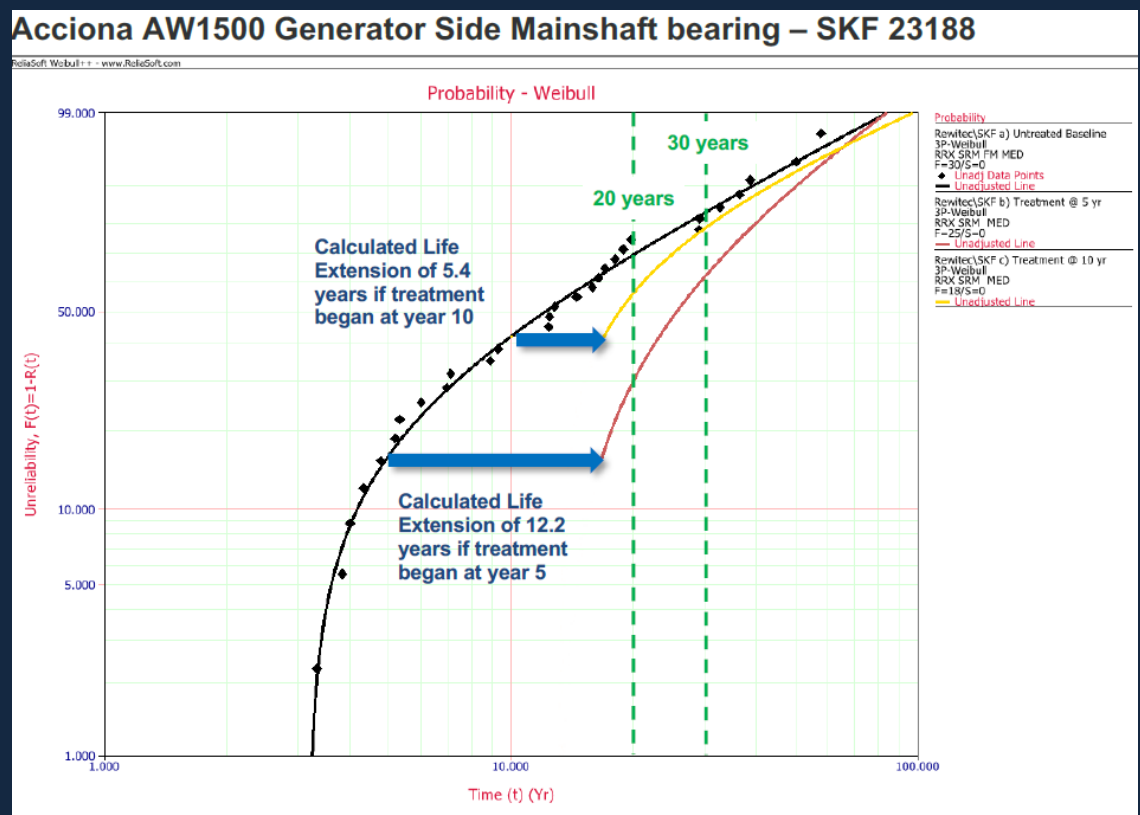

⇒ Results:

- ⇒ Significant reduction in the probability of failure of a main bearing by REWITEC™
- ⇒ Less roughness
- ⇒ Less friction
- ⇒ More even load distribution
- ⇒ Lower local pressure/ stress

⇒ The earlier the application, the greater the effect

Sentient Science Lifetime calculation

⇒ Mainshaft Bearing Life Extension by REWITEC™ GR400 Grease using Sentient Science' DigitalClone®

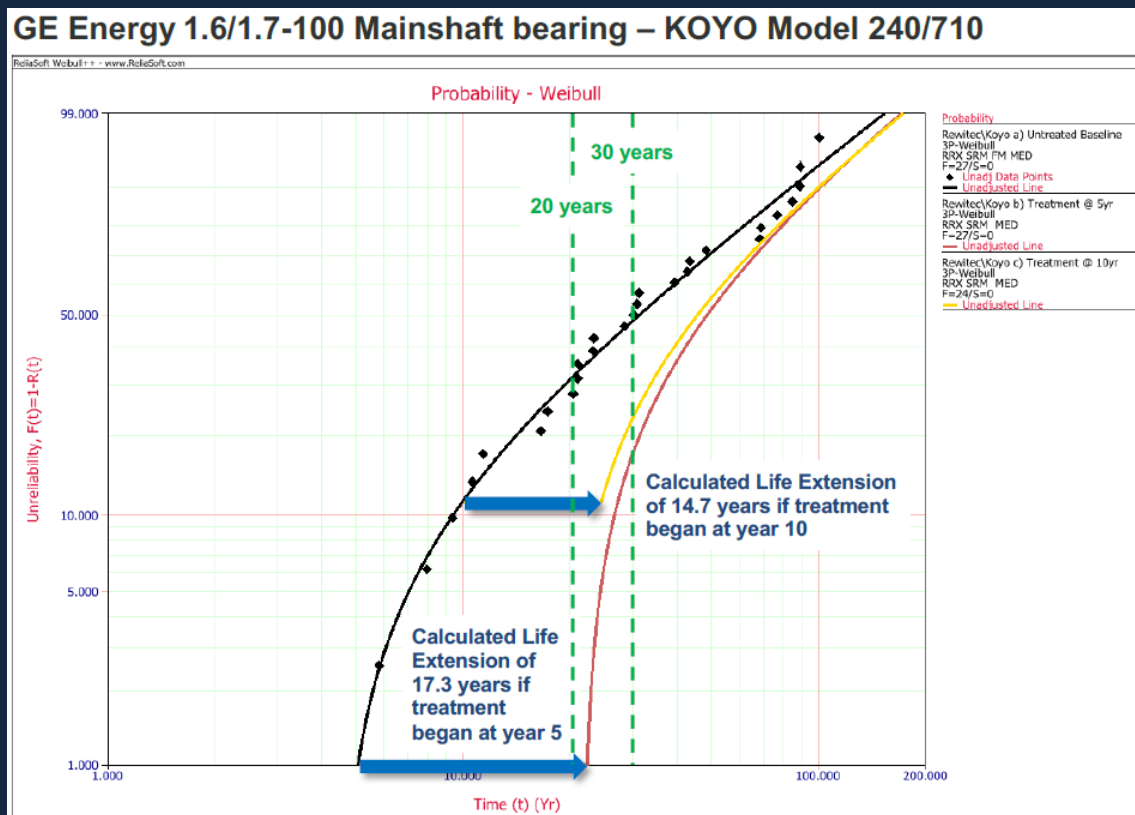

⇒ Results:

- ⇒ Significant reduction in the probability of failure of a main bearing by REWITEC™
- ⇒ Less roughness
- ⇒ Less friction
- ⇒ More even load distribution
- ⇒ Lower local pressure/ stress

⇒ The earlier the application, the greater the effect

Conclusion

Conclusion

- ⇒ Less surface roughness and friction in the drive train system means:
 - ⇒ Less temperature, stress and wear for the gearbox and bearings
 - ⇒ Less stress for the lubricants
 - ⇒ Protecting and repairing effect
 - ⇒ Higher system efficiency
 - ⇒ Higher reliability and availability, no downtime
 - ⇒ Significant lifetime improvement
 - ⇒ Cost savings, higher earnings



Our services



Component surface
imprinting



Component damage
analysis and reporting



Technical advice,
including up-tower
inspections



Part of Croda International Plc

If you need more support – Please contact us.

REWITEC GmbH
Dr.-Hans-Wilhelmi-Weg 1
35633 Lahnau
Germany

Tel.: +49 6441 445990
E-mail: stefan.bill@rewitec.com
www.rewitec.com

Smart science to improve lives™

Supported by:



Federal Ministry
for Economic Affairs
and Energy

on the basis of a decision
by the German Bundestag

Made in
Germany

CRODA